

# YMC Glass Columns

For Laboratory  
Scale Applications



**Biocompatible**

**Self-packing**

**Easy Handling**

# YMC Glass Columns

**B**iochromatography is widely used for high-performance downstream processing techniques for a wide range of compounds, including proteins, peptides or nucleic acids. When using various chromatographic tech-

niques such as ion exchange, affinity or gel permeation chromatography, high-performance separation media are increasingly used and, as a result, higher demands are made on the quality of the column hardware.

Laboratory Scale:

## ECO and ECO<sup>PLUS</sup> Glass Columns

ECO columns are glass columns for use with almost all types of soft gels and medium pressure liquid chromatography applications.

ECO<sup>PLUS</sup> columns meet the highest criteria for professional laboratory use. Particular attention has been paid to the column volume ranges and the pressure resistance, so that high flow rates, performance and efficiency can be achieved.



# Contents

<b>Selection Guide</b> .....	<b>4</b>
<b>Glass columns for analytical and preparative MPLC applications: ECO</b> .....	<b>5–17</b>
Specifications.....	8–9
Chemical Resistance.....	10–11
Packing Adapters.....	12–13
Ordering Guide.....	14–15
Accessories and Spare Parts.....	16–17
<b>ECO and ECO<sup>PLUS</sup> Glass Column Accessories</b> .....	<b>18–19</b>
<b>Column Version Overview</b> .....	<b>20–21</b>
<b>Glass columns for high pressure applications: ECO<sup>PLUS</sup></b> .....	<b>23–35</b>
Specifications.....	26–27
Chemical Resistance.....	28–29
Packing Adapters.....	30–31
Accessories and Spare Parts.....	32–33
Ordering Guide.....	34–35
<b>Training and Seminars</b> .....	<b>36</b>
<b>Laboratory Services</b> .....	<b>37</b>
<b>Also of interest</b> .....	<b>38</b>
<b>Questionnaire for YMC Glass Columns</b> .....	<b>39</b>

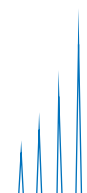

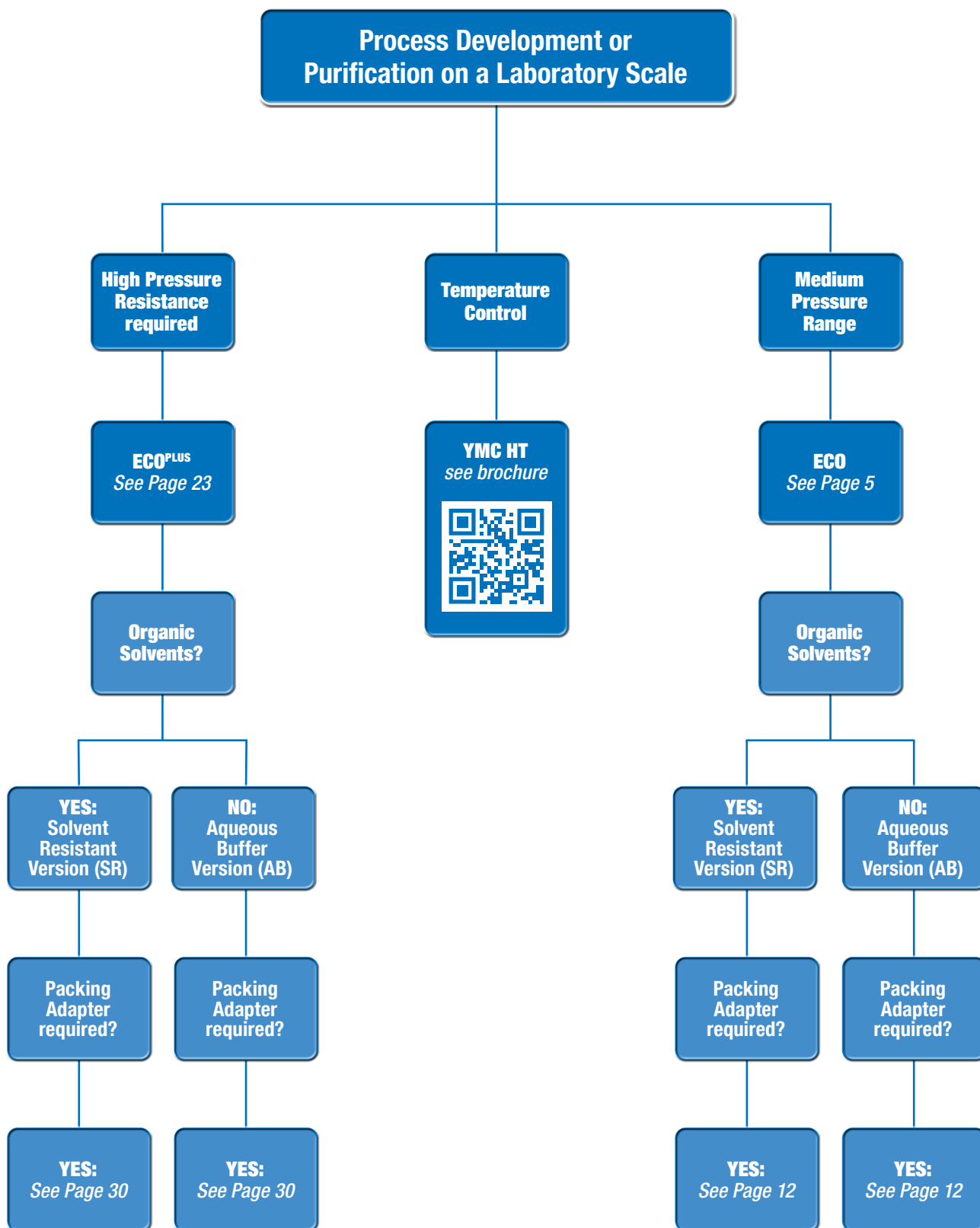

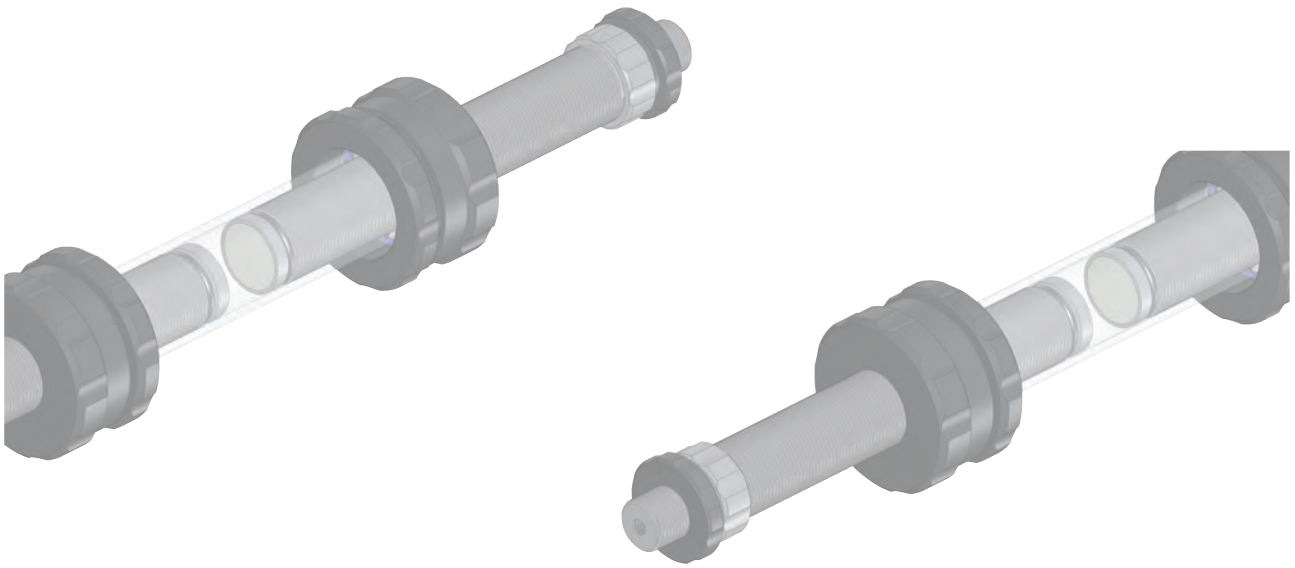

# ECO Glass Columns

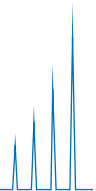
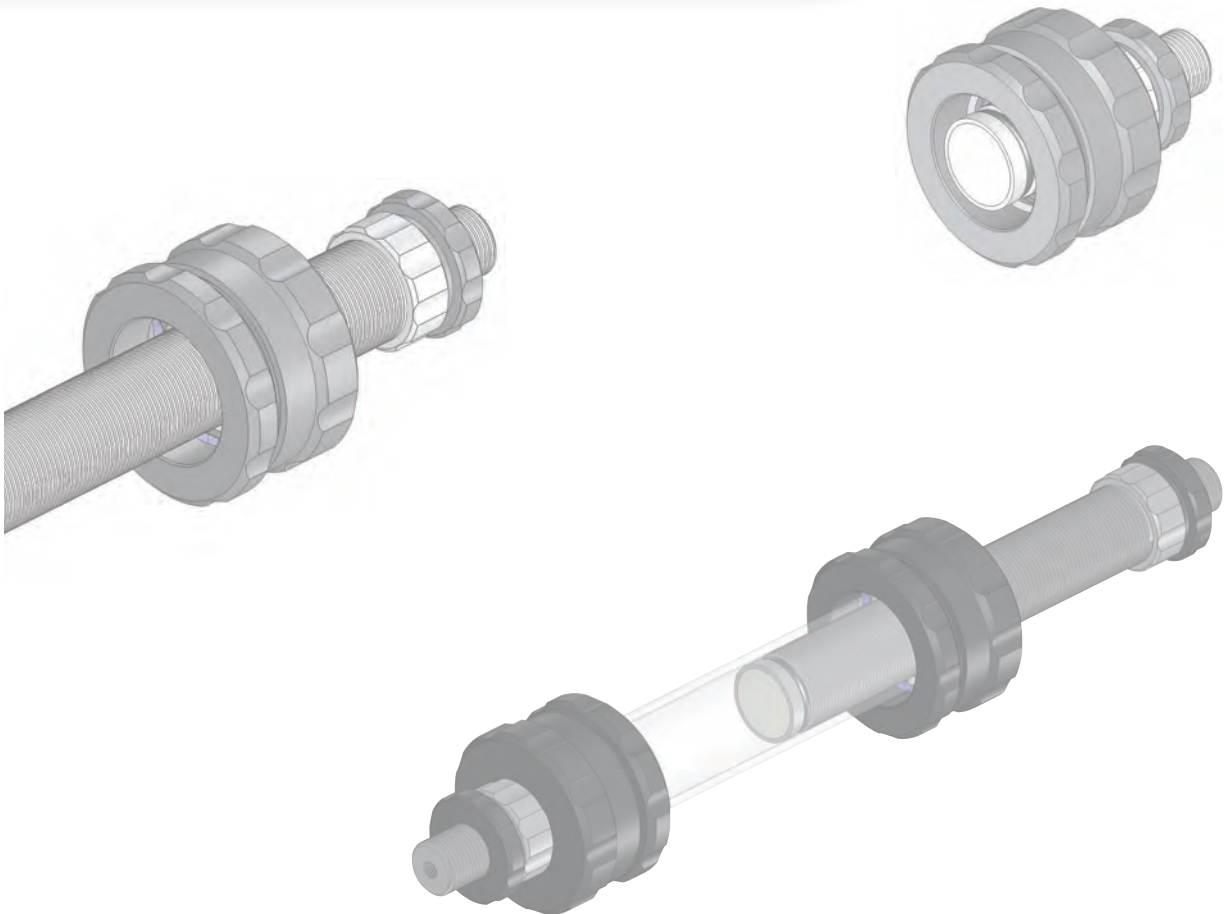

# ECO Glass Columns

- **First choice for medium pressure liquid chromatography (MPLC)**
- **Pressure limit 30–5 bar**
- **25, 50, 70 and 80 mm ID columns with column stands available**
  
- Compatible with any LC system
- For all types of silica and soft gels
- Aqueous buffers and solvents
- Temperature range 4–40°C
- Easy self-packing

ECO columns are glass columns suitable for all types of soft gel and medium pressure (pressure limit 30–5 bar) liquid chromatography applications. With a choice of one or two adjustable length pistons, they are available in two versions: **AB (aqueous buffer)** for use with aqueous buffers and cold room applications and **SR (solvent resistant)** for all forms of normal and reversed phase chromatography.

ECO columns are produced using high-precision CNC manufacturing. They are competitively priced and equipped with a screw-lock system which makes it possible to open and seal the column simply and quickly. Each column passes a quality control pressure test.

# Drawing of Variable Column End Piece – ECO

- 1. Frit
- 2. O-ring
- 3. External piston
- 4. Inner piston
- 5. Counter screw
- 6. Spring washer
- 7. Snap ring
- 8. Counter nut
- 9. Screw nut

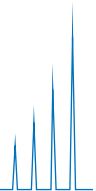
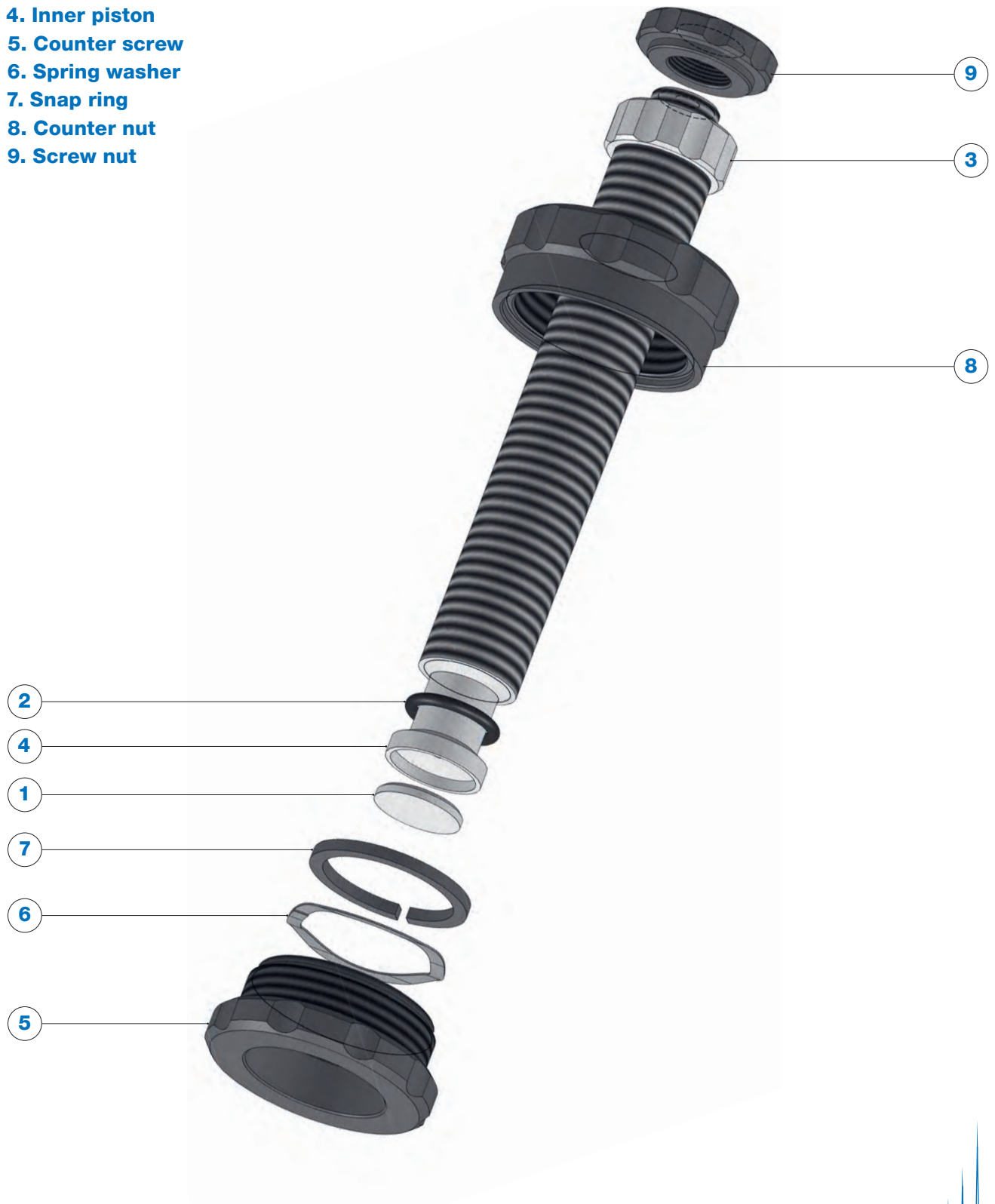

# Specifications

Parameter	Standard Columns
Inner Diameter [mm]	10, 15, 25, 50, 70, 80
Length Glass Body [mm]	120, 200, 450, 750, 1000
Pressure Range* [bar]	30–5
Temperature Range [°C]	4–40

Versions	AB (Aqueous Buffer)
	SR (Solvent Resistant)
Combinations Of Pistons	Two adjustable pistons: Multivario
	One adjustable piston: Vario

Wetted Parts	AB: POM pistons, glass or PE frits, FKM or EPDM O-ring, borosilicate glass body
	SR: PVDF pistons, glass or stainless steel frits, FFKM O-ring, borosilicate glass body
Connections	The columns are supplied with different adapters to allow direct connection to any LC-system (e.g. ÄKTA sytem)
Accessories Supplied (columns with ID 10–15 mm)	1 x frit removal tool 2 x plugs, PTFE (1/4"-28G) 1 x 2 m FEP tubing (0.8 x 1.6 mm) 4 x 1/4"-28G nut and ferrule for 1/16" tubing 2 x M6 nut and ferrule for 1/16" tubing 2 x 10-32 fitting for 1/16" tubing
Accessories Supplied (columns with ID 25–80 mm)	1 x frit removal tool 2 x plugs, PTFE (1/4"-28G) 1 x 2 m FEP tubing (1.6 x 3.2 mm) 4 x 1/4"-28G nut and ferrule for 1/8" tubing 2 x M6 nut and ferrule for 1/8" tubing

\*Pressure limit depends on inner diameter.

# Specifications

**Your benefit of Multivario option:  
Greater flexibility due to  
expanded bed length and  
column volume ranges!**

## What is the difference between Vario and Multivario options?

Adjustable and non-adjustable (fixed) pistons are available for the ECO columns.

Two different options are available for combining these two pistons:

- 1. Vario: One adjustable and one fixed piston**
- 2. Multivario: Two adjustable pistons**

The selection of the option depends on the required ranges of bed lengths and column volumes.

Inner diameter column (mm)	Pressure limit (bar)	One adjustable piston (Vario)		Two adjustable pistons (Multivario)	
		Bed length range (mm)	Column volume range (mL)	Bed length range (mm)	Column volume range (mL)
10	30	0-120	0-9	0-120	0-9
		80-200	7-15	0-200	0-15
		330-450	28-35	220-450	19-35
		630-750	54-58	520-750	44-58
		880-1000	75-78	780-1000	66-78
15	25	0-120	0-19	0-120	0-19
		80-200	16-32	0-200	0-32
		330-450	63-73	210-450	40-73
		630-750	120-122	510-750	97-122
		880-1000	163-163	760-1000	145-163
25	15	0-120	0-60	0-120	0-60
		80-200	50-100	0-200	0-100
		330-450	190-230	220-450	130-230
		630-750	365-390	520-750	300-390
		880-1000	510-520	770-1000	445-520
50	10	0-120	0-235	0-120	0-235
		80-200	180-390	0-200	0-390
		330-450	730-885	230-450	510-885
		630-750	1390-1480	530-750	1170-1480
		880-1000	1945-1970	780-1000	1725-1970
70	5			0-120	0-425
				0-200	0-710
				70-450	290-1610
				370-750	1530-2680
				620-1000	2560-3570
80	5			0-120	0-560
				0-200	0-940
				70-450	380-2120
				370-750	1980-3530
				620-1000	3320-4710

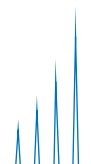

# Chemical resistance

On the following two pages, the chemical resistances (standard conditions) for the available standard versions are listed.

## ECO – AB version

Solvent	Columns with 10–50 mm ID POM piston, FKM O-ring and glass frit	Columns with 70–80 mm ID POM piston, EPDM O-ring and PE frit
Acetone	Not resistant	Resistant
Acetonitrile	Limited resistant	Limited resistant
Ammonium dihydrogen phosphate	Limited resistant	Resistant
Cyclohexane	Resistant	Not resistant
Dichloromethane	Limited resistant	Not resistant
EDTA (3%)	Resistant	Resistant
Acetic acid (6%)	Resistant	Resistant
Ethanol	Resistant	Resistant
Ethyl acetate	Not resistant	Limited resistant
n-hexane	Resistant	Not resistant
Isopropanol	Resistant	Resistant
Methanol	Limited resistant	Resistant
NaOH (2M)	Limited resistant	Resistant
HCl (1M)	Not resistant	Not resistant
Urea (8M)	Resistant	Resistant
NaCl (1M)	Resistant	Resistant
Na <sub>2</sub> SO <sub>4</sub> (0.5M)	Resistant	Resistant

Not resistant

Limited resistant

Resistant

# Chemical resistance

## ECO – SR version

Solvent	Columns with 10–50 mm ID PVDF piston, FFKM O-ring and glass frit	Columns with 70–80 mm ID PVDF piston, FFKM O-ring and stainless steel frit
Acetone	Not resistant	Not resistant
Acetonitrile	Limited resistant	Limited resistant
Ammonium dihydrogen phosphate	Resistant	Limited resistant
Cyclohexane	Resistant	Resistant
Dichloromethane	Limited resistant	Limited resistant
EDTA (3%)	Resistant	Resistant
Acetic acid (6%)	Resistant	Limited resistant
Ethanol	Resistant	Resistant
Ethyl acetate	Limited resistant	Limited resistant
n-hexane	Resistant	Resistant
Isopropanol	Resistant	Resistant
Methanol	Resistant	Resistant
NaOH (2M)	Resistant	Limited resistant
HCl (1M)	Resistant	Not resistant
Urea (8M)	Resistant	Resistant
NaCl (1M)	Resistant	Limited resistant
Na <sub>2</sub> SO <sub>4</sub> (0.5M)	Resistant	Limited resistant

Not resistant

Limited resistant

Resistant

If your solvent is not listed, please contact us for chemical resistance check.

**Note:** The resistance of the standard versions is based on the resistance of the each wetted part. If one part is limited or not resistant, the whole column is marked with this characteristic as it is the critical part thereof.

For all columns, where the combination of the wetted parts varies from the above listed ones, the chemical resistance can vary, too. Therefore, please contact us if you need assistance regarding the chemical resistance.

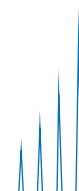

# Packing Adapters

For more information on column packing download the ECO manual or visit one of our seminars!

## Do I need a packing adapter?

Packing adapters are used if the packing method requires additional column volume during the packing process.

More volume than given by the column alone may be required when the column is packed with the slurry method. A suspension of material and packing sol-

vent in a concentration of approximately 30–50% is used, depending on the packing material. The additional packing solvent above the finished column bed will be removed later but during the packing process the packing adapter gives the additional volume which is required for this method.

1. Coupling unit
2. Snap ring
3. Spring washer
4. Counter screw
5. Glass body

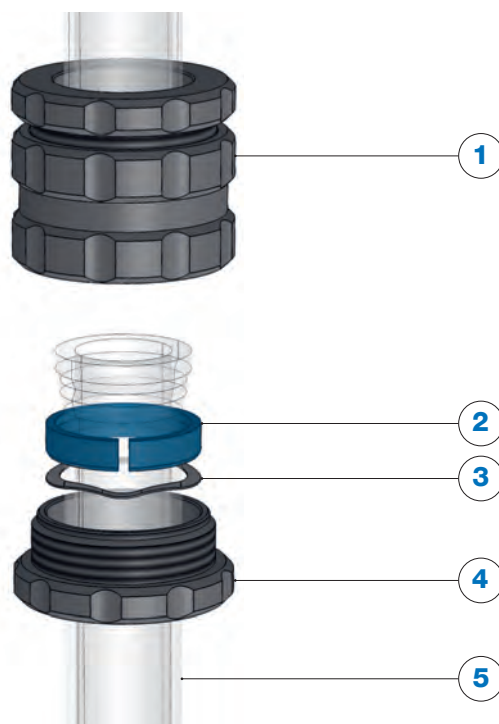

## What are the components of the packing adapter?

The ECO series packing adapters consist of a column coupler and an empty glass body. These must be of the same diameter as the column to be packed and must be used as packing adapters, not for ex-

tending the length of a column body during use. The product manual supplied with each column contains detailed examples of dry packing and slurry packing techniques.

## How to install the packing adapter?

1. Remove the upper end piece from the column body.
2. Put the counter screw of the coupling unit on the column body.  
Take care that just the blue column coupler snap ring is included.
3. Install the end piece on top of the glass body of the packing adapter.

*One of our lab services is glass column packing with your choice of material.*

# Packing Adapters

## How to order a packing adapter?

### 1. Select the correct column coupler

	Inner diameter column	Identification for coupling unit	O-ring
<b>Combinations</b>	<b>ECO10</b> (10 mm ID) <b>ECO15</b> (15 mm ID) <b>ECO25</b> (25 mm ID) <b>ECO50</b> (50 mm ID) <b>ECO70</b> (70 mm ID) <b>ECO80</b> (80 mm ID)	<b>KU/</b>	<b>V-3 FKM</b> (AB, 10–50 mm ID)  <b>E EPDM</b> (AB, 70–80 mm ID)  <b>K-3 FFKM</b> (SR, 10–50 mm ID)
<b>Example</b>	<b>ECO10</b>	<b>KU/</b>	<b>V-3</b>
Inner diameter column	10 mm		
O-ring			10 mm ID column, AB version, FKM O-ring

### 2. Select the correct glass body

Glass bodies with the following dimensions are available:

Inner diameter (mm)	10, 15, 25, 50, 70, 80
Column length (mm)	120, 200, 450, 750, 1000

The length of the additional glass body used should be selected to allow:

- **Double the volume of slurry compared to the required packed bed volume if packing silica materials**
- **Triple the volume of slurry for softer packing materials**

The part number for the glass body is:

**ECOID/length e.g. ECO10/120**

*If you need assistance in choosing the right packing adapter, please contact YMC!*

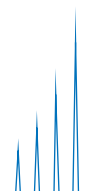

# Ordering Guide

The part numbers for the columns contain information on the column type, inner diameter, maximum bed length, piston type, frit porosity and seal (O-ring) material. In brackets, the corresponding ordering code is quoted.

## 1. Inner diameter of your column:

Inner Diameter [mm]	Pressure Limit [bar]
10 (ECO10)	30
15 (ECO15)	25
25 (ECO25)	15
50 (ECO50)	10
70 (ECO70)	5
80 (ECO80)	5

## 2. Maximum bed length

Maximum bed length [mm]
120 (120)
200 (200)
450 (450)
750 (750)
1000 (999)

## 3. Piston Type

I adjustable pistons: Vario (V)

II adjustable pistons: Multivario (M)

## 4. Frits

Porosity
10–16 $\mu\text{m}$ (0)
16–40 $\mu\text{m}$ (3)
40–100 $\mu\text{m}$ (4)

## 5. O-rings

Material
FKM (V): AB versions, 10–50 mm ID
EPDM (E): AB versions, 70–80 mm ID
FFKM (K): SR versions, 10–80 mm ID

# Ordering Guide

	Inner diameter column	Maximum bed length	Combination of pistons	Frit Porosity	O-ring material
<b>Combination</b>	<b>ECO10/</b> (10 mm)	<b>120</b> (max. 120 mm)	<b>V</b> (I adjustable piston)	<b>0</b> (10–16 µm)	<b>V</b> (FKM, AB)
	<b>ECO15/</b> (15 mm)	<b>200</b> (max. 200 mm)	<b>M</b> (II adjustable pistons)	<b>3</b> (16–40 µm)	<b>E</b> (EPDM, AB)
	<b>ECO25/</b> (25 mm)	<b>450</b> (max. 450 mm)			
	<b>ECO50/</b> (50 mm)	<b>750</b> (max. 750 mm)			
	<b>ECO70/</b> (70 mm)	<b>999</b> (max. 1000 mm)			
	<b>ECO80/</b> (80 mm)				
<b>Example</b>	<b>ECO10/</b>	<b>120</b>	<b>M</b>	<b>0</b>	<b>K</b>
Inner diameter column	10 mm				
Max. bed length		120 mm			
Combination of pistons			2 adjustable pistons (Multivario)		
Frit porosity				10–16 µm	
O-ring material					Solvent resistant version, FFKM

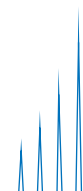

## Accessories and Spare Parts

**1. Column Stand:** A column stand is available for ECO columns with 25, 50, 70 and 80 mm ID.

**2. Packing adapter:** Packing adapters are available for all available inner diameters in different lengths. For more information, see pages 12 and 13.



## Accessories and Spare Parts

**End Pieces:** Assembly includes inner/external piston, counter nut and screw, screw nut, snap ring, spring washer, O-ring and frit

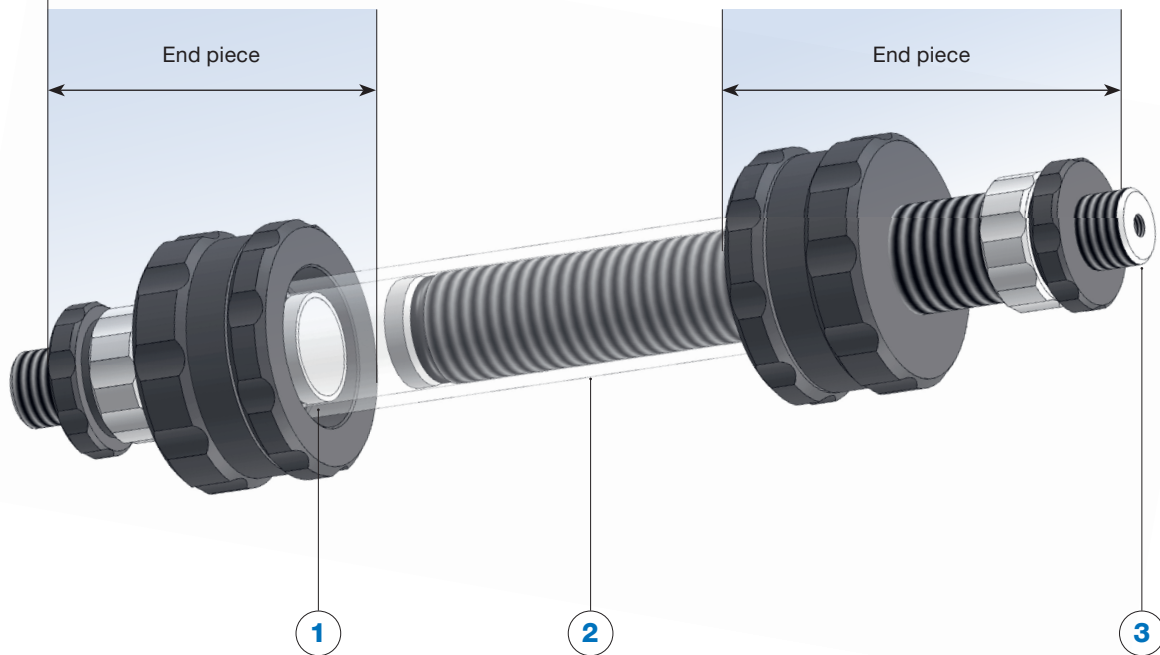

1. O-rings and frits
2. Glass body
3. Fittings and tubing/Accessory pack

For ordering accessories or spare parts, please contact [YMC!](#)

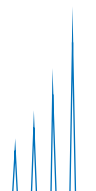

## Easy Connection of YMC Glass Columns to Äkta Systems

YMC have specifically designed an adapter to allow easy connection of YMC glass columns to Äkta systems. This adapter will allow direct connection of the 10-32 fittings of the Äkta systems

to the inlets and outlets of YMC glass columns. This adapter is compatible to all existing YMC glass columns with internal diameters between 10 to 50mm and can be ordered as a pack of 2 pieces.

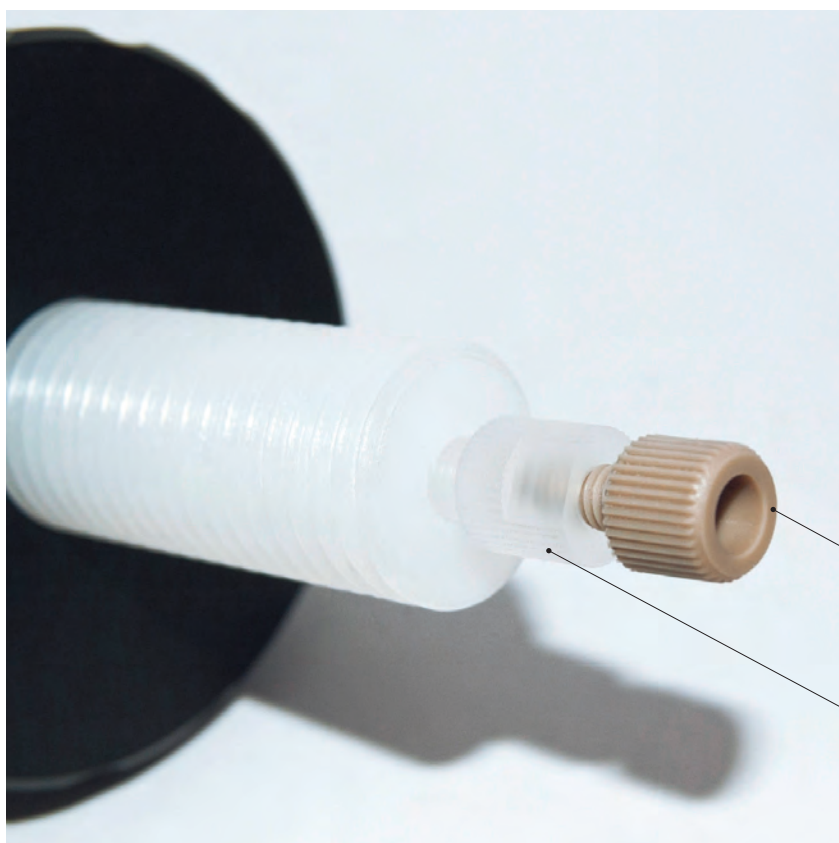

10-32 fitting

YMC Adapter

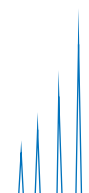



This tool helps you to open and close YMC glass columns.

The Handling-Loop is universally applicable to all available inner diameters of YMC HT, ECO and ECO<sup>PLUS</sup> glass column ranges.

**Ordering information**

**Product number: Handling-Loop**

Universal strap wrench for YMC HT, ECO and ECO<sup>PLUS</sup> columns (ID 5–80 mm)

**The advantages of using the Handling-Loop**

- ✓ Simplified opening of glass columns
- ✓ Universally applicable
- ✓ Easy grip especially with larger inner diameters

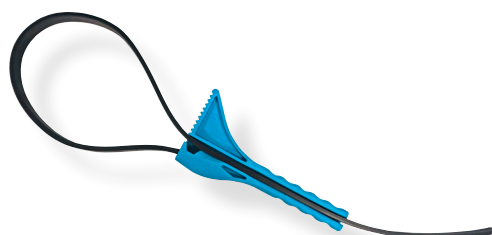

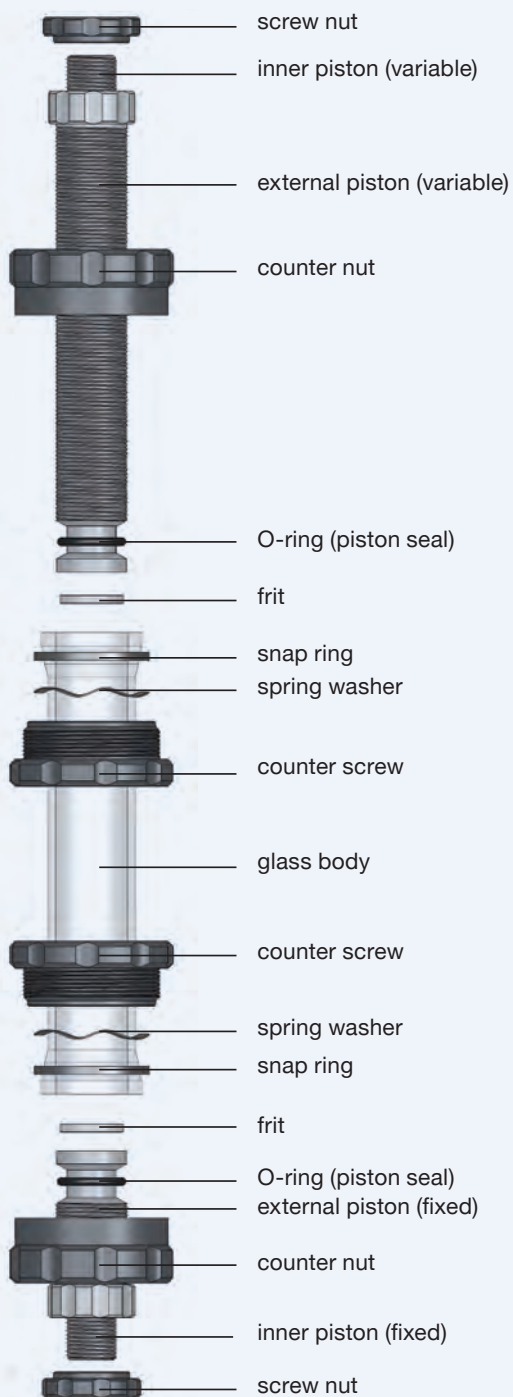

# ECO

**10, 15, 25, 50, 70, 80 mm ID**

**120, 200, 450, 750, 1000 mm  
max. bed lengths**

**Solvent resistant (SR) and  
aqueous buffer (AB) versions**

**AB & SR: 4–40 °C**

**30–5 bar**

**Pistons:  
POM, PVDF**

**Sealing:  
FKM, EPDM, FFKM**

**Frits:  
PE, glass or stainless steel**

**Glass Body:  
Borosilicate glass 3.3**

# ECO<sup>PLUS</sup>

5, 10, 15, 25, 35, 50 mm ID

125, 250, 500 mm  
max. bed lengths

Solvent resistant (SR) and  
aqueous buffer (AB) versions

AB: 4–40 °C,  
SR: 16–40 °C

80–15 bar

Pistons:  
PE, PTFE

Sealing:  
EPDM, PTFE, FFKM

Frits:  
PE, glass or stainless steel

Glass Body:  
KPG\* Borosilicate glass 3.3

(\*calibrated precision glass)

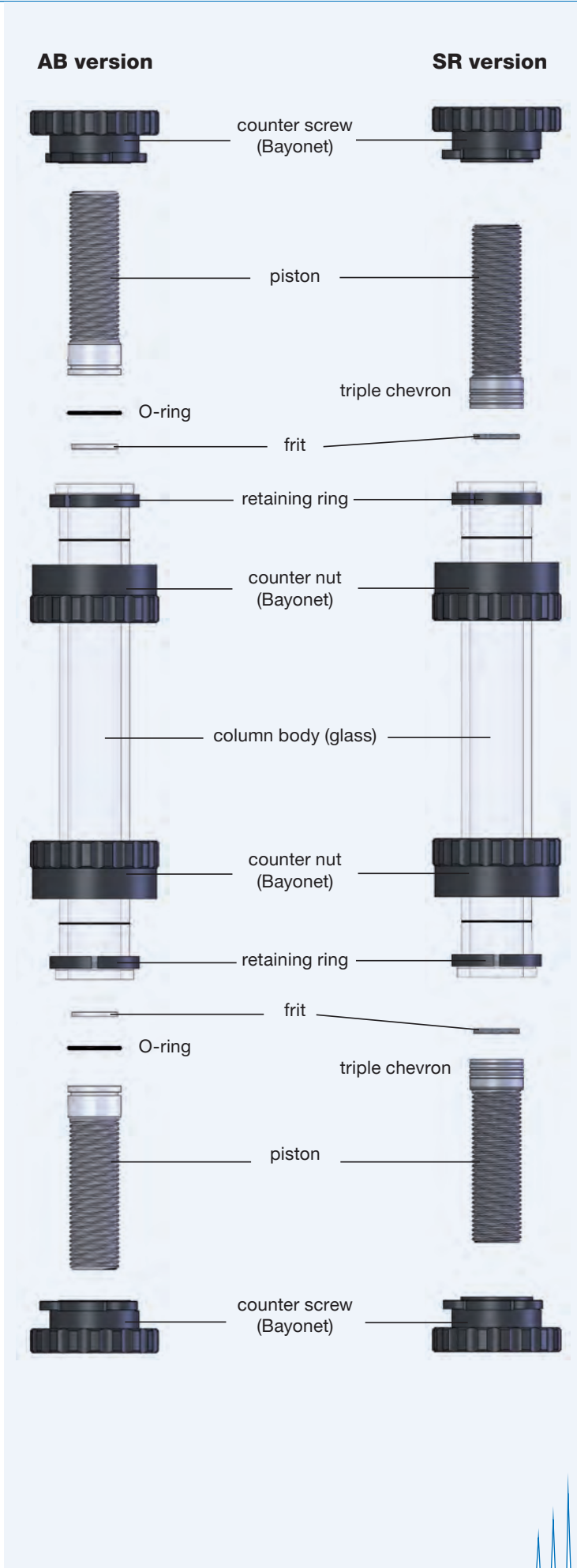



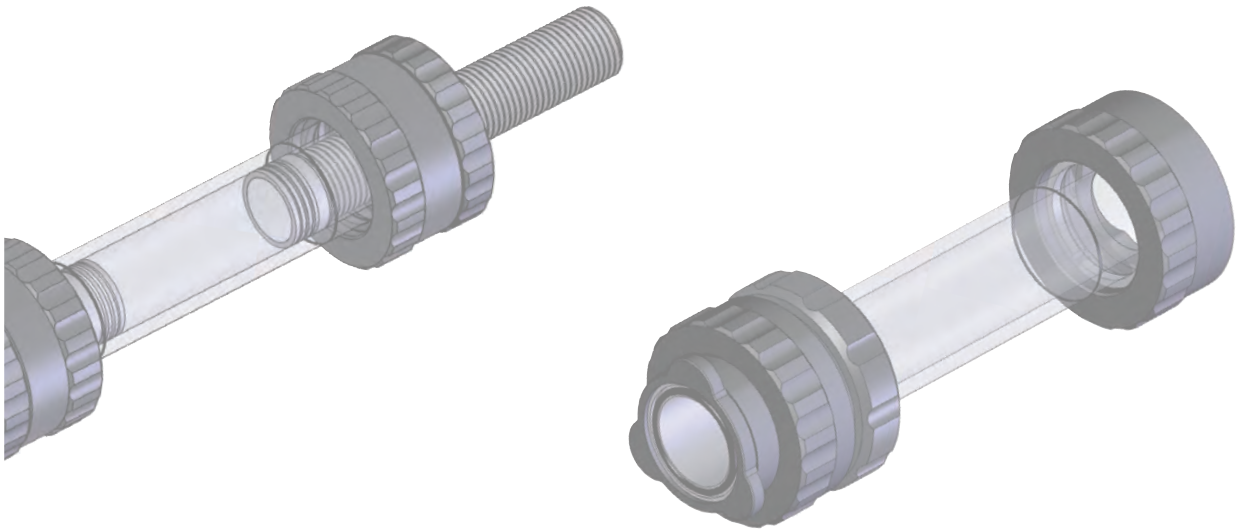

# ECO<sup>PLUS</sup> Glass Columns

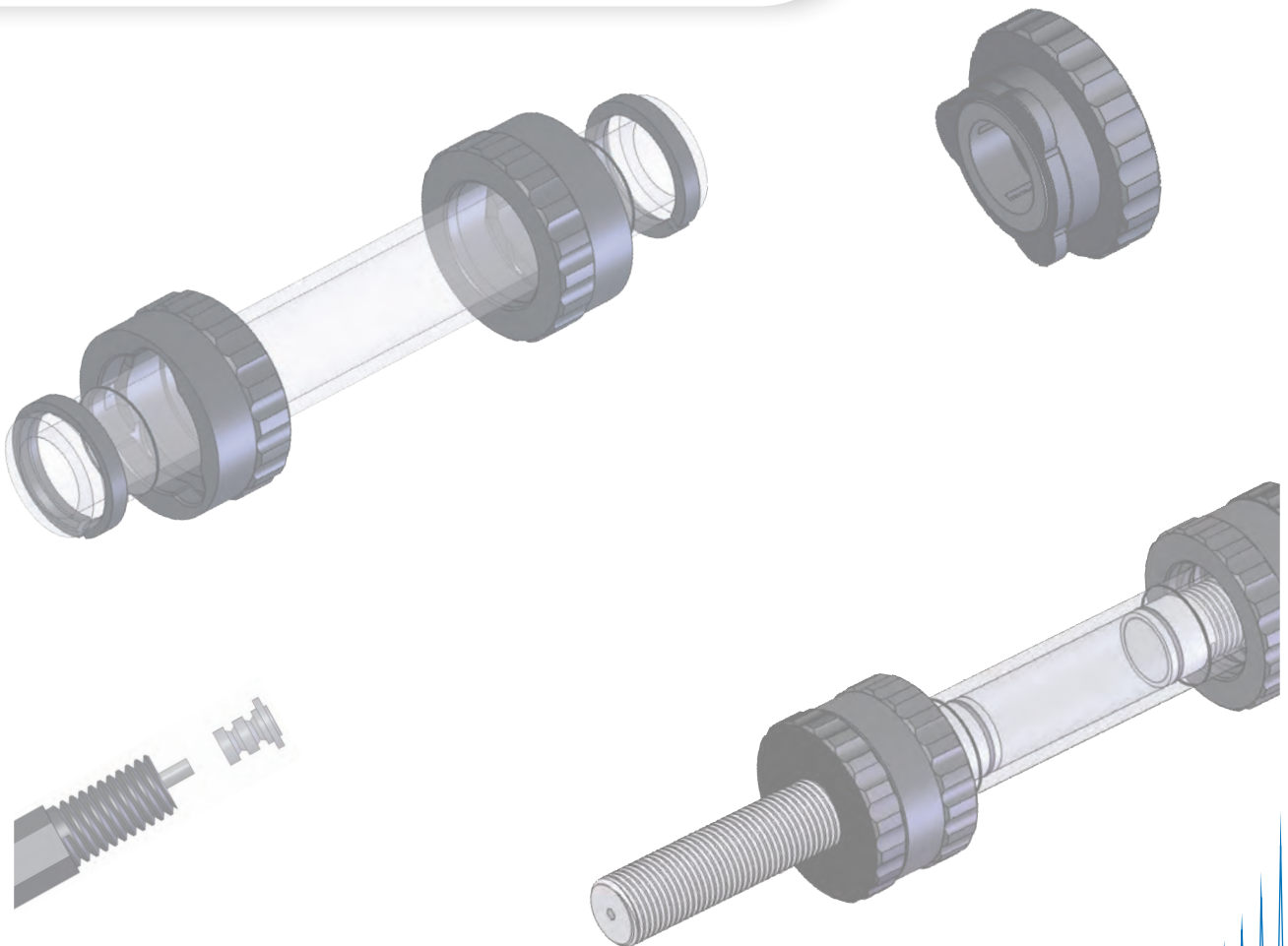

# ECO<sup>PLUS</sup> Glass Columns

- **First choice for high pressure application (preparative HPLC)**
- **Pressure limit: 80–15 bar**
- **Columns with 5 mm ID available**
  
- Compatible with any LC system
- For all types of silica and soft gels
- Aqueous buffers and organic solvents
- Temperature range 4–40 °C (AB) or 16–40 °C (SR)
- Easy self packing

ECO<sup>PLUS</sup> columns are multi-purpose columns for all types of liquid chromatography applications even with high operating pressures. The columns are available in two versions:

- 1. Aqueous buffer version (AB):**  
**For applications with aqueous buffers**
  
- 2. Solvent resistant version (SR):**  
**For applications with organic solvents**

Three different combinations of pistons are available for a wide range of bed lengths and volumes.

The solvent resistant pistons are equipped with Teflon chevrons for sealing (except 50 mm ID), the AB versions with O-rings.

ECO<sup>PLUS</sup> columns are suitable for the entire spectrum of normal phase and reversed phase chromatography as well as biochromatography.

All columns are produced in the YMC Europe facilities in Germany. The high pressure resistance is guaranteed by a special construction of the column including the locking system (Quick-Lock).

The high-quality columns are made using high precision CNC machines and undergo several rigorous quality controls before they are delivered.

# Drawing of ECO<sup>PLUS</sup> Solvent Resistant End Piece

1. Frit
2. Piston
3. Counter nut (Bayonet)

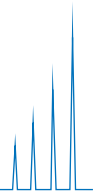
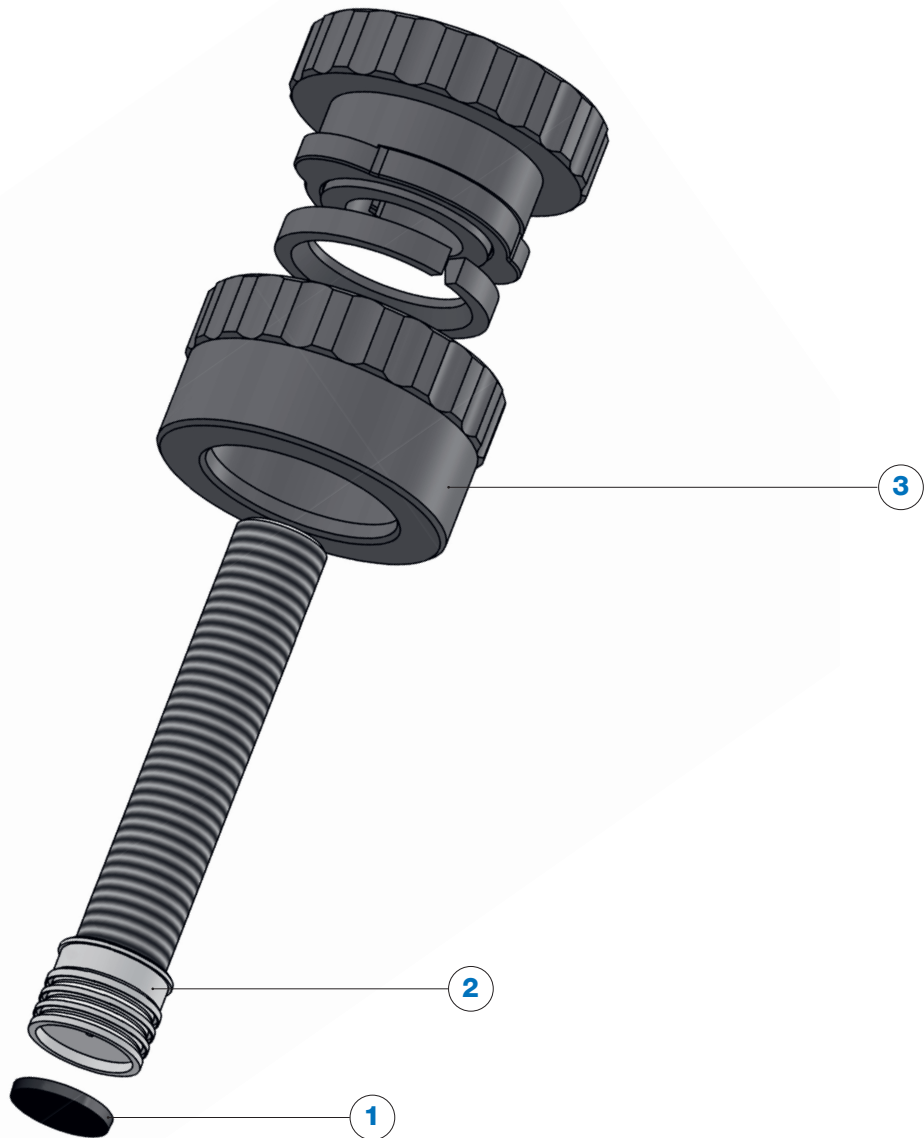

# Specifications

Parameter	Standard Columns
Inner Diameter [mm]	5, 10, 15, 25, 35, 50
Length Glass Body [mm]	125, 250, 500
Pressure Range* [bar]	80–15
Temperature Range [°C]	AB: 4–40, SR: 16–40

<b>Versions</b>	AB (Aqueous Buffer)
	SR (Solvent Resistant)
<b>Combinations Of Pistons</b>	Short (Two short pistons)
	Short/long (One short and one long piston)
	Long (Two long pistons)

<b>Wetted Parts</b>	AB: PE pistons, PE frits, EPDM O-ring, KPG borosilicate glass 3.3 body
	SR: PTFE pistons, glass or stainless steel frits, PTFE chevrons or FFKM O-ring, KPG borosilicate glass body
<b>Connections</b>	The columns are supplied with different adapters to allow direct connection to any LC-system (e.g. ÄKTA system)
<b>Accessories Supplied</b> (columns with ID 5 mm)	<ul style="list-style-type: none"> <li>1 x frit removal tool</li> <li>2 x plugs, PTFE (1/4"-28G)</li> <li>1 x 1 m ETFE 1/16" capillary tubing pre-assembled</li> <li>4 x 1/4"-28G screws and ferrules for 1/16" tubing</li> <li>2 x M6 screws and ferrules for 1/16" tubing</li> <li>2 x 10-32 fitting for 1/16" tubing</li> </ul>
<b>Accessories Supplied</b> (columns with ID 10–15 mm)	<ul style="list-style-type: none"> <li>1 x frit removal tool</li> <li>2 x plugs, PTFE (1/4"-28G)</li> <li>1 x 2 m FEP 1/16" capillary tubing (0.8 x 1.6 mm)</li> <li>4 x 1/4"-28G screws and ferrules for 1/16" tubing</li> <li>2 x M6 screws and ferrules for 1/16" tubing</li> <li>2 x 10-32 fitting for 1/16" tubing</li> </ul>
<b>Accessories Supplied</b> (columns with ID 25–50 mm)	<ul style="list-style-type: none"> <li>1 x frit removal tool</li> <li>2 x plugs, PTFE (1/4"-28G)</li> <li>1 x 2 m FEP 1/8" capillary tubing (1.6 x 3.2 mm)</li> <li>4 x 1/4"-28G screws and ferrules for 1/8" tubing</li> <li>2 x M6 screws and ferrules for 1/8" tubing</li> </ul>

# Specifications

## What is the difference between Short, Short/Long and Long?

For the ECO<sup>PLUS</sup> column short and long pistons are available which can be combined in three different ways:

1. **Short:**           **Two short pistons**
2. **Short/Long:** **One short and one long piston**
3. **Long:**           **Two long pistons**

The choice of the version depends on the required ranges of bed lengths and column volumes.

Inner diameter (mm)	Short Pistons		Short/Long Pistons		Long Pistons	
	Bed length range (mm)	Volume range (mL)	Bed length range (mm)	Volume range (mL)	Bed length range (mm)	Volume range (mL)
<b>5</b>	30–125	0.6–2.4	0–125	0–2.4	0–125	0–2.4
	150–250	3.0–4.9	70–250	1.4–4.9	0–250	0–4.9
	400–500	7.9–9.8	320–500	6.3–9.8	240–500	4.8–9.8
<b>10</b>	40–125	3.2–9.8	0–125	0–9.8	0–125	0–9.8
	160–250	13–19	80–250	6.2–19	0–250	0–19
	410–500	33–39	330–500	26–39	250–500	20–39
<b>15</b>	30–125	6–22	0–125	0–22	0–125	0–22
	155–250	28–44	75–250	14–44	0–250	0–44
	405–500	72–88	325–500	58–88	245–500	44–88
<b>25</b>	30–125	15–60	0–125	0–60	0–125	0–60
	160–250	80–120	80–250	40–120	0–250	0–120
	410–500	205–245	330–500	165–245	250–500	125–245
<b>35</b>	35–125	35–120	0–125	0–120	0–125	0–120
	160–250	155–240	80–250	80–240	0–250	0–240
	410–500	395–480	330–500	320–480	250–500	245–480
<b>50</b>	40–125	80–245	0–125	0–245	0–125	0–245
	170–250	335–490	90–250	180–490	0–250	0–490
	415–500	815–980	340–500	670–980	255–500	500–980

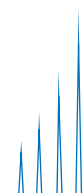

## Pressure resistance

In order to guarantee the high pressure stability, special materials and a unique end piece system including the Quick-Lock system are used for the ECO<sup>PLUS</sup> columns. The pressure resistance depends on the inner diameter and the column version (AB or SR).

Inner Diameter [mm]	Pressure Limit [bar]
5	AB version: 80 bar, SR version: 80 bar
10	AB version: 80 bar, SR version: 50 bar
15	AB version: 70 bar, SR version: 50 bar
25	AB version: 50 bar, SR version: 50 bar
35	AB version: 40 bar, SR version: 40 bar
50	AB version: 30 bar, SR version: 15 bar

## Chemical resistance

On the following two pages, the chemical resistances (standard conditions) for the available standard versions are listed.

### ECO<sup>PLUS</sup> – AB version

Solvent	Columns with 5–50 mm ID, PE pistons, PE frits, EPDM O-rings
Acetone	Resistant
Acetonitrile	Limited resistant
Ammonium dihydrogen phosphate	Resistant
Cyclohexane	Not resistant
Dichloromethane	Not resistant
EDTA (3%)	Resistant
Acetic acid (6%)	Resistant
Ethanol	Resistant
Ethyl acetate	Limited resistant
n-hexane	Not resistant
Isopropanol	Resistant
Methanol	Resistant
NaOH (2M)	Resistant
HCl (1M)	Resistant
Urea (8M)	Resistant
NaCl (1M)	Resistant
Na <sub>2</sub> SO <sub>4</sub> (0.5M)	Resistant

Not resistant

Limited resistant

Resistant

# Chemical resistance

## ECO<sup>PLUS</sup> – SR version

Solvent	Columns with 5 – 35 mm ID, PTFE piston, PTFE triple chevron lamellar seals, glass/stainless steel frits	Columns with 50 mm ID, PTFE pistons, FFKM O-rings, stainless steel frits
Acetone	Resistant	Resistant
Acetonitrile	Resistant	Resistant
Ammonium dihydrogen phosphate	Limited resistant	Limited resistant
Cyclohexane	Resistant	Resistant
Dichloromethane	Resistant	Resistant
EDTA (3%)	Resistant	Resistant
Acetic acid (6%)	Limited resistant	Limited resistant
Ethanol	Resistant	Resistant
Ethyl acetate	Resistant	Resistant
n-hexane	Resistant	Resistant
Isopropanol	Resistant	Resistant
Methanol	Resistant	Resistant
NaOH (2M)	Limited resistant	Limited resistant
HCl (1M)	Limited resistant	Limited resistant
Urea (8M)	Resistant	Resistant
NaCl (1M)	Limited resistant	Limited resistant
Na <sub>2</sub> SO <sub>4</sub> (0.5M)	Limited resistant	Limited resistant

Limited resistant

Resistant

If your solvent is not listed or you need a resistant column version which is not listed, please contact us for chemical resistance check or a custom made version.

**Note:** The resistance of the standard versions is based on the resistance of the each wetted part. If one part is limited or not resistant, the whole column is marked with this characteristic as it is the critical part thereof.

For all columns, where the combination of the wetted parts varies from the above listed ones, the chemical resistance can vary, too. Therefore, please contact us if you need assistance regarding the chemical resistance.

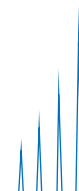

For more information on column packing download the ECO<sup>PLUS</sup> manual or visit one of our seminars!

# Packing Adapters

## Do I need a packing adapter?

Packing adapters are used if the packing methods requires additional column volume during the packing process.

More volume than given by the column is required when the column is packed with the slurry method. A suspension of material and packing solvent in a

concentration of approximately 30–50% is used, depending on the packing material. The additional packing solvent above the finished column bed will be removed later but during the packing process the packing adapter gives the additional volume which is required for this method.

1. Snap ring (column version)
2. Counter nut (bayonet)
3. Glass body  
(not included in column coupler)
4. Column coupler counter nut
5. Column coupler snap ring
6. Connection screw (bayonet)
7. O-ring
8. Teflon inset
9. O-ring

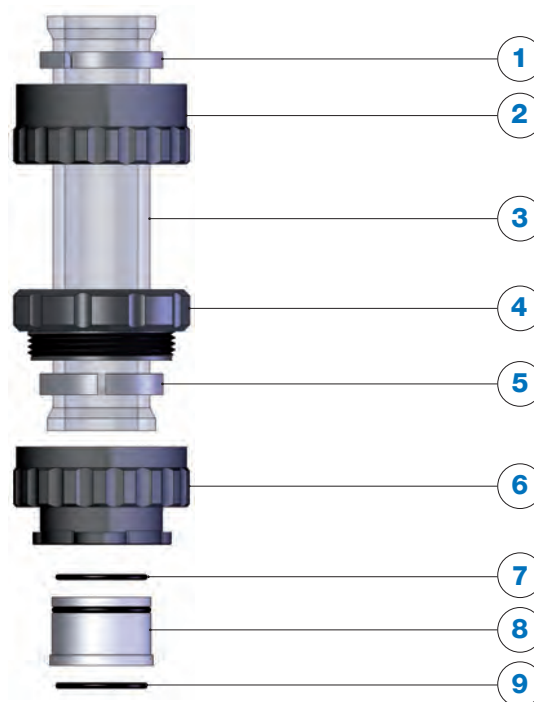

## What are the components of the packing adapter?

The ECO<sup>PLUS</sup> series of packing adapters consist of a column coupler and an empty glass body. These must be of the same diameter as the column to be packed and must be used as packing adapt-

ers, not for extending the length of a column body during use. The product manual supplied with each column contains detailed examples of dry packing and slurry packing techniques.

## How to install the packing adapter?

1. Remove the upper end piece from the column.
2. Add the column coupler counter nut (bayonet) including the column coupler snap ring to the column body.
3. Fix the connection screw and the counter nut first. Fix the column coupler counter nut afterwards.

# Packing Adapters

One of our lab services  
is glass column packing  
with your material!

## How to order a packing adapter?

### 1. Select the right column coupler

	Inner diameter column	Identification for coupling unit	O-ring
<b>Combinations</b>	TAC05 (5 mm ID) TAC10 (10 mm ID) TAC15 (15 mm ID) TAC25 (25 mm ID) TAC35 (35 mm ID) TAC50 (50 mm ID)	KU	-AB FKM O-ring  -SR FFKM O-ring
<b>Example</b>	<b>TAC10</b>	<b>KU</b>	<b>-AB</b>
Inner diameter column	10 mm		
O-ring			FKM for aqueous buffer version

### 2. Select the right glass body

Glass bodies with the following dimensions are available:

Inner diameter (mm)	5, 10, 15, 25, 35, 50
Column length (mm)	125, 250, 500

The length of the additional glass body used should be selected to allow:

- **Double the volume of slurry compared to the required packed bed volume if packing silica materials**
- **Triple the volume of slurry for softer packing materials**

The part number for the glass body is:

**TACID/length-2 e.g. TAC10/125-2**

If you need assistance in choosing the right packing adapter, please contact [YMC!](#)

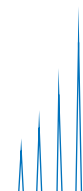

# Accessories and Spare Parts

ECO<sup>PLUS</sup> AB version

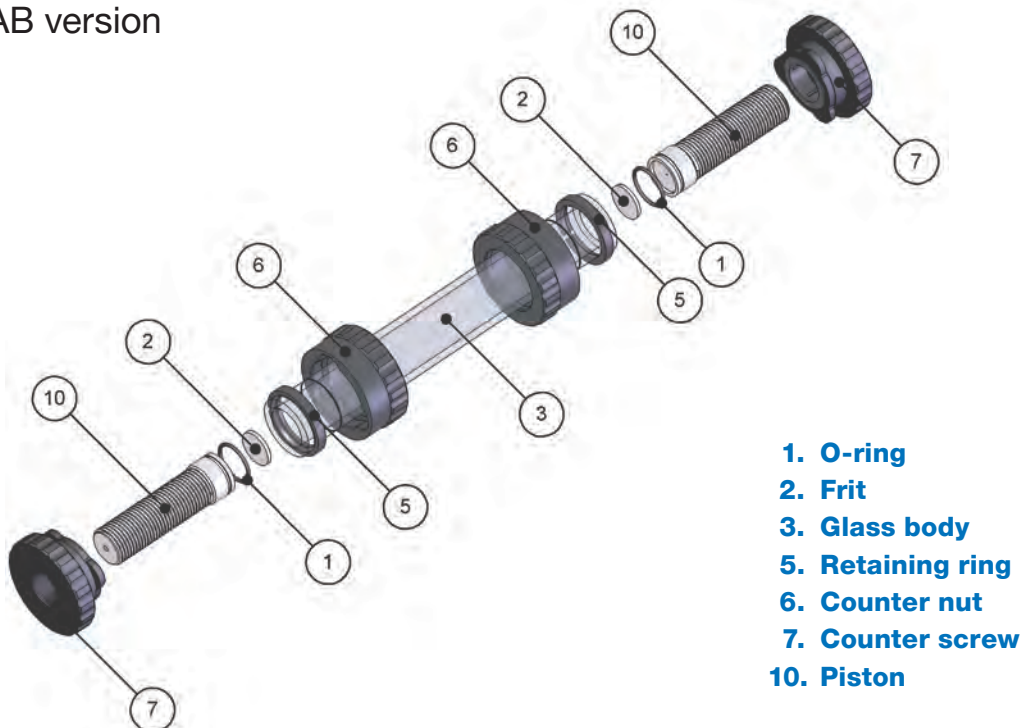

ECO<sup>PLUS</sup> SR version

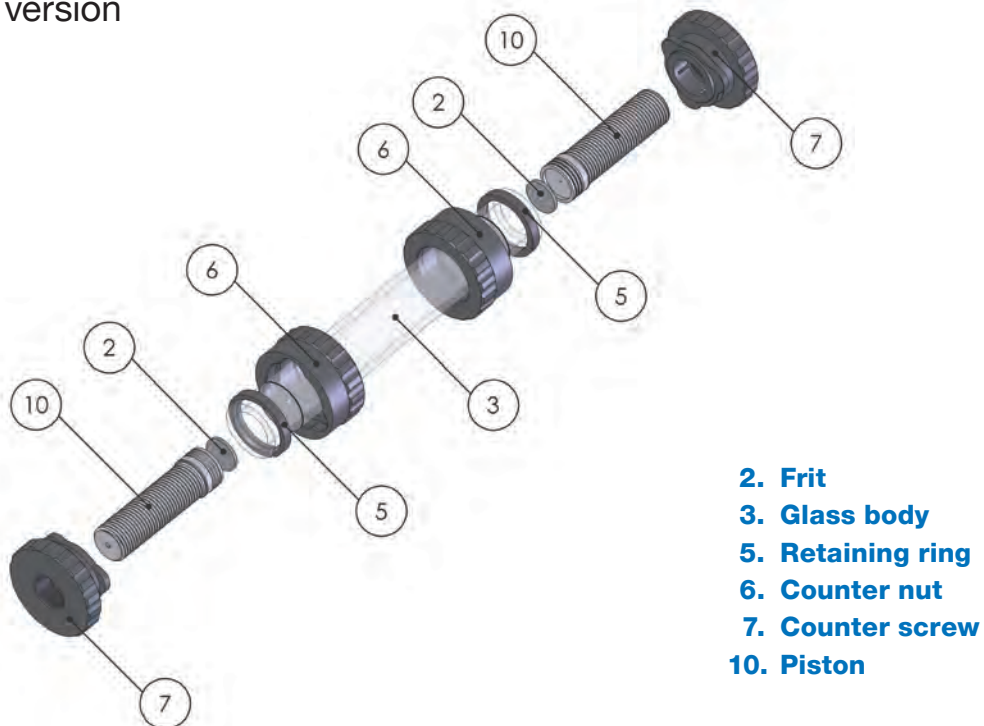

# Accessories and Spare Parts

Spare parts available for ECO<sup>PLUS</sup> glass columns:

- Glass bodies
- Pistons
- O-rings
- Frits

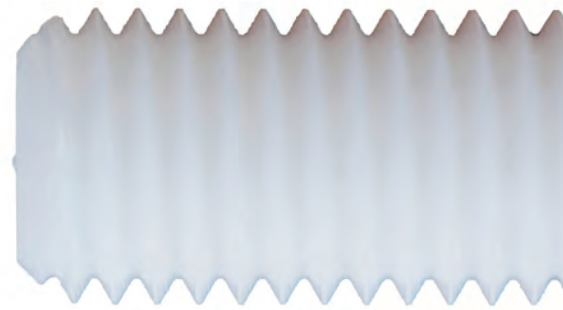

Accessories available for ECO<sup>PLUS</sup> glass columns:

- Coupling units
- Tubing
- Fittings (nuts and ferrules) and adapters



For the complete listing of all available accessories and spare parts and their related ordering codes, please request our pricelists as PDF files.

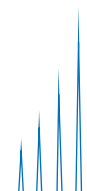

# Ordering Guide

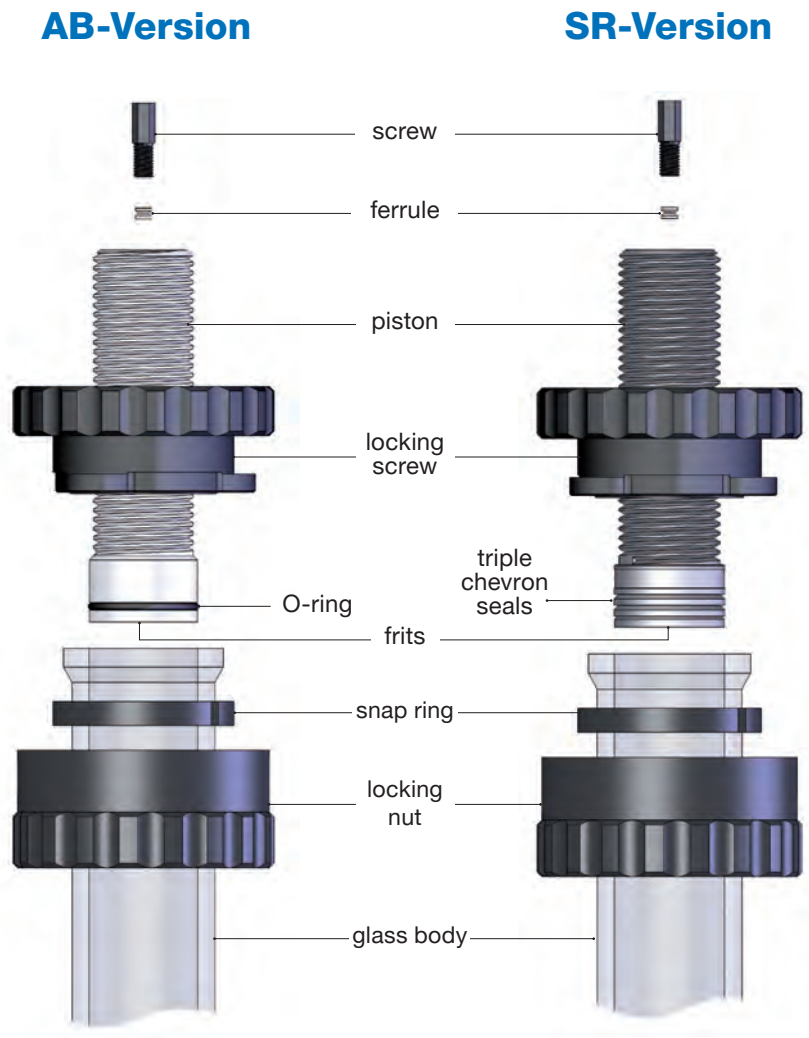

# Ordering Guide

	Inner diameter column	Maximum bed length	Combination of pistons	Frit material	Frit porosity	Version
<b>Combinations</b>	<b>TAC05/</b> (5 mm ID)	<b>125</b> (max. 125 mm)	<b>-</b> (2 short pistons)	<b>PE</b> (polyethylene, AB version)	<b>2</b> (2 µm)	<b>-AB-2</b> (aqueous buffer)
	<b>TAC10/</b> (10 mm ID)	<b>250</b> (max. 250 mm)	<b>SL</b> (1 short + 1 long piston)	<b>G</b> (sintered glass, SR version ≤ 15 mm ID)	<b>5</b> (5 µm, only for PE)	<b>-SR-2</b> (solvent resistant)
	<b>TAC15/</b> (15 mm ID)					
	<b>TAC25/</b> (25 mm ID)	<b>500</b> (max. 500 mm)	<b>L</b> (2 long pistons)	<b>S</b> (stainless steel, SR version ≥ 25 mm ID)	<b>0</b> (10 µm)	<b>-SR-NK</b> (solvent resistant, 50 mm ID)
	<b>TAC35/</b> (35 mm ID)					
	<b>TAC50/</b> (50 mm ID)					
<b>Example</b>	<b>TAC25/</b>	<b>500</b>		<b>S</b>	<b>2</b>	<b>-SR-2</b>
Inner diameter column	25 mm					
Max. bed length		500 mm				
Combination of pistons			2 short pistons			
Frit material				stainless steel		
Frit porosity					2 µm	
Version						Solvent resistant

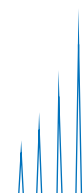

# Training and Seminars

## Glass Column Packing – Laboratory Scale and Pilot Columns

This training will enable you to pack laboratory and process scale columns – using theory as well as practical experience. Different packing methods and procedures for preparing the packing process will be discussed. In the hands-on part of the training, you will pack a column yourself in our application laboratory. Helpful tips for troubleshooting and method optimisation will complement the seminar.

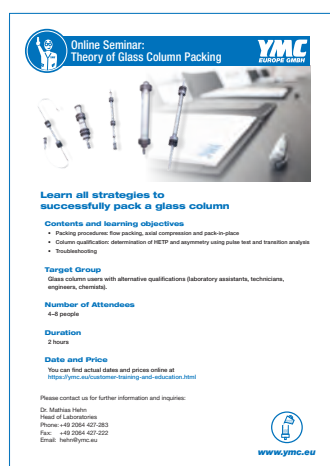

### Contents and Learning Objectives

- How to achieve your packed column – packing methods you can use
- Basics of preparation
- Hands-on experience – all steps you require for packing your column
- How you determine column efficiency
- Troubleshooting – what you can learn from column performance evaluation results

### Target group

Glass column users with alternative qualifications (laboratory assistants, technicians, engineers, chemists)

You can find actual dates for seminars in our seminar flyer at [www.ymc.eu](http://www.ymc.eu) or you can contact us directly:

Phone: +49 2064 427-0

Fax: +49 2064 427-222

Email: [info@ymc.eu](mailto:info@ymc.eu)

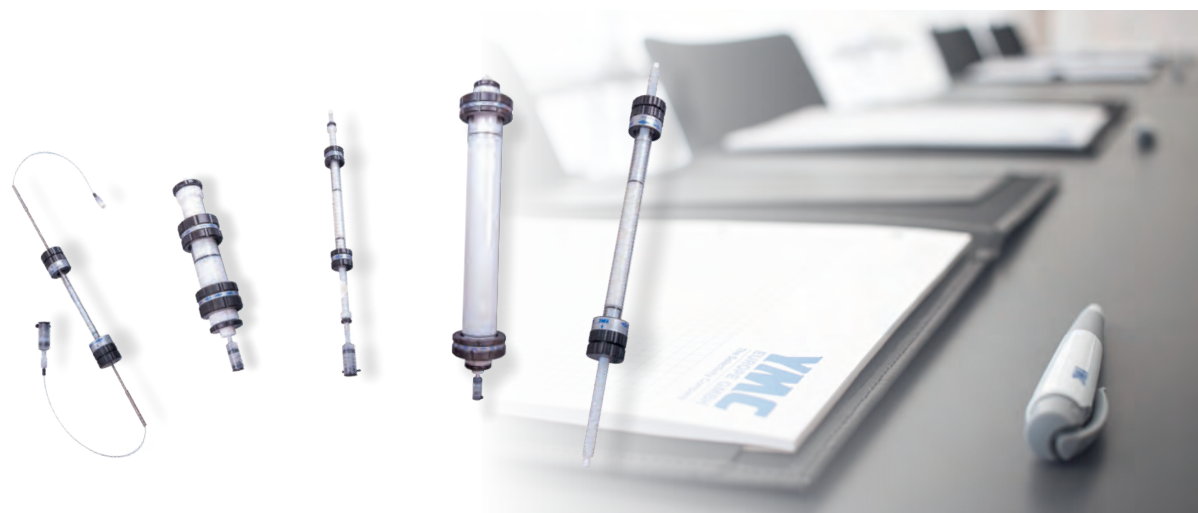

# Laboratory Services

## Save time and choose a packed column

If you are working on a tight schedule or you do not have sufficient experience in column packing here is a solution!

Rely on the experience of YMC and ask for a packed YMC HT, ECO or ECO<sup>PLUS</sup> column. Our knowledge of packing is your benefit!

## Our services include packing of

- **YMC HT, ECO and ECO<sup>PLUS</sup> columns**

Depending on your required bed length, you can choose a column from our portfolio. If you can't find a suitable standard product, we will gladly discuss the options of a customised column with you.

- **New glass columns and refill of your used YMC HT, ECO or ECO<sup>PLUS</sup> column**

A second option for purchasing new column hardware is to use the option of our refill service if you already have a YMC HT, ECO or ECO<sup>PLUS</sup> column. This service includes changing of frits and a quality control for the glass columns.

- **Stationary phases from YMC as well as from other suppliers**

If your method is restricted to a certain stationary phase, we pack your column according to your needs, using stationary phases made by YMC or any other supplier.

## How it works:

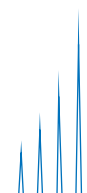

## Also of interest

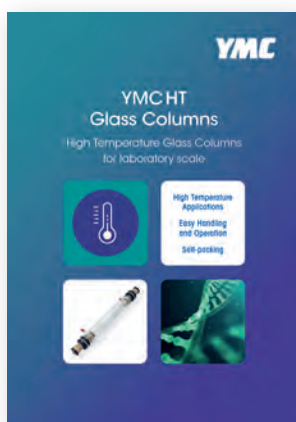

YMC HT is the new standard for temperature sensitive applications. The innovative design allows an operation under high temperatures up to 70°C with reliable results.



YMC's BioPro IEX are polymeric ion exchange resins for the purification of biologicals. They represent one part of the three part YMC-Prep portfolio: silica, hybrid silica and polymer media.

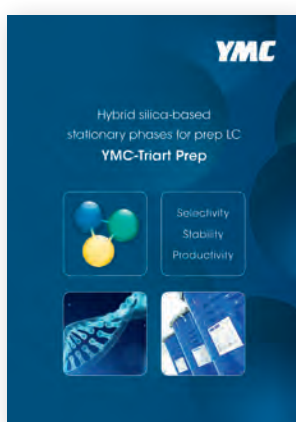

YMC-Triart Prep is a hybrid silica phase, stable between pH 2.0–10.0. It is available with various modifications for RP purifications.

For help in selecting your laboratory or pilot scale glass column, please fill in this questionnaire and send a scan to [info@ymc.eu](mailto:info@ymc.eu).

## Questionnaire for YMC Glass Columns

1. Inner diameter (mm): \_\_\_\_\_

2. Minimum bed length (mm): \_\_\_\_\_

3. Maximum bed length (mm): \_\_\_\_\_

4. Bed volume (mL): \_\_\_\_\_

5. Maximum pressure (bar): \_\_\_\_\_

6. Biocompatibility: yes  no

7. Packing material: \_\_\_\_\_

8. Particle size of packing material: \_\_\_\_\_

9. Solvents: \_\_\_\_\_

10. Operating temperature: \_\_\_\_\_

11. Quotation for packing adapter required: yes  no

12. Regulatory requirements: \_\_\_\_\_

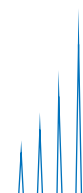

Your local distributor:

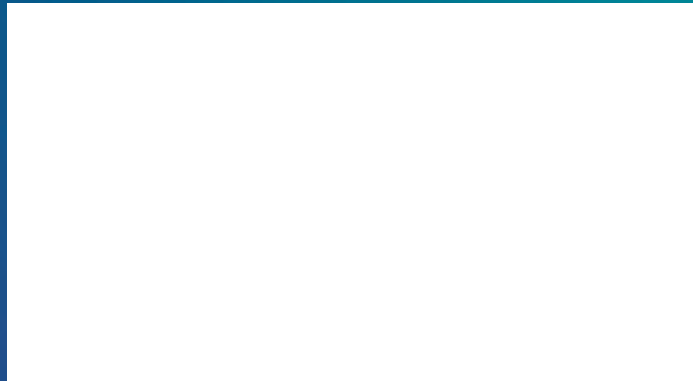

**YMC Europe GmbH**

Schöttmannshof 19  
D-46539 Dinslaken  
Germany  
Phone +49 2064 427-0, Fax +49 2064 427-222  
[www.ymc.eu](http://www.ymc.eu)

**YMC Schweiz GmbH**

Im Wasenboden 8  
4056 Basel  
Switzerland  
Phone +41 61 561 80-50, Fax +41 61 561 80-59  
[www.ymc-schweiz.ch](http://www.ymc-schweiz.ch)

**YMC CO., LTD.**

YMC Karasuma-Gojo Bld. 284 Daigo-cho,  
Karasuma Nishiiru Gojo-dori Shimogyo-ku,  
Kyoto 600-8106 Japan  
Phone +81 75342 451-5, Fax +81 75342 45-50  
[www.ymc.co.jp](http://www.ymc.co.jp)