

# Optimum Column Positioning with ECO Column Stands!

For optimum positioning next to your system, YMC offers column stands for ECO glass columns. Due to the reliable and handy design, setting up the column was never faster and easier.

**No tools are required for secured fixation!**

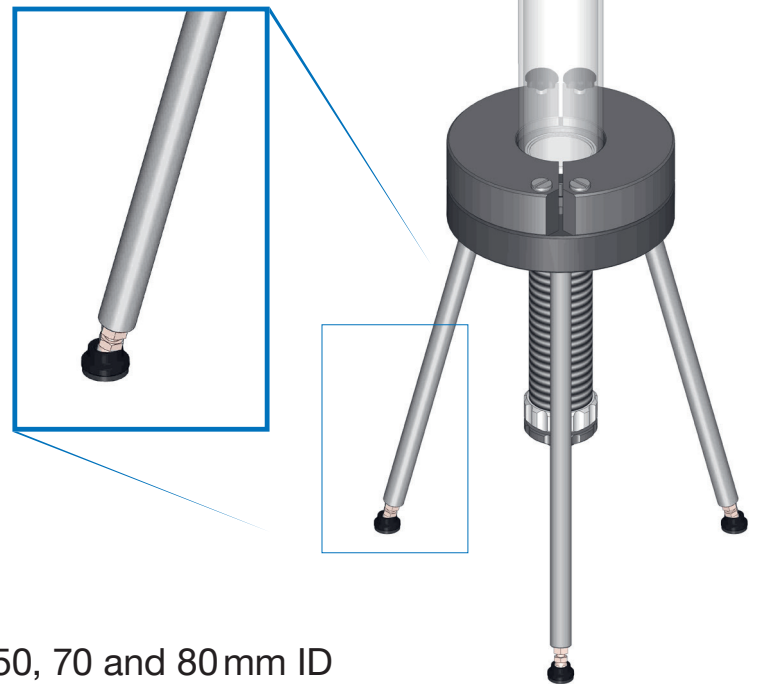

Your advantages are:

- ✓ **Wide portfolio:** Stands for 25, 50, 70 and 80 mm ID
- ✓ **High stability:** Screwed in feet for secure grip
- ✓ **Perfect alignment:** The feet are equipped with leveling feet

Part-No.	Description
ECO25/FUSS-3	Stand for 25 mm ID
ECO50/FUSS-3	Stand for 50 mm ID
ECO70/FUSS-3	Stand for 70 mm ID
ECO80/FUSS-3	Stand for 80 mm ID

**Contact us now and  
order YMC column stands  
for your ECO glass columns!**